

ZIJN JULIE KLAAR VOOR DE TERUGKEER?

art3f 
Internationale beurs voor hedendaagse kunst

Gallery
ART FAIR

END OF
**BLACK
SUMMER**

-50%

LET OP!

**ER ZAL GEEN BLACK FRIDAY
AANBIEDING
IN NOVEMBER ZIJN**

*Plan nu alvast je beurzen voor
2024 en 2025 met de End of
Black Summer-aanbieding
van -50%!*

AANBIEDING GELDIG TOT 30 SEPTEMBER 2024

onder voorbehoud van beschikbaarheid van de stands die aan deze aanbieding zijn toegewezen en niet cumuleerbaar met andere reeds lopende aanbiedingen (Discovery-aanbieding, Pack-aanbiedingen, Ledenaanbieding, etc.). Volledige betaling bij ontvangst van de factuur.

- ✓ Aanbod geldig voor **alle beurzen van het 2e semester van 2024 en het jaar 2025**
- ✓ Mogelijkheid om **één of meerdere data te kiezen**
- ✓ **Aanbod beperkt tot uiterlijk middernacht op 30 september**, maar ook, om een financieel evenwicht te waarborgen, **beperkt door een aantal contracten per stad**
- ✓ Invoering van **een uitzonderlijk selectiecomité** om u binnen **24 uur een antwoord te geven**

END OF BLACK SUMMER

KALENDER

Aanbod beperkt door aantal contracten
toegewezen aan elke stad (zie hieronder)

2024

LUXEMBURG (Luxemburg)

HAUTE-SAVOIE

MARSEILLE

LAUSANNE ART FAIR (Zwitserland)

ALLEEN GERESERVEERD VOOR GALERIES

MULHOUSE

BRUSSEL (België)

BORDEAUX

27>29 september 2024

04>06 oktober 2024

18>20 oktober 2024

31 okt.>03 november 2024

15>17 november 2024

22>24 november 2024

06>08 december 2024

2025

ZÜRICH (Zwitserland)

PARIJS

TOULOUSE

STRAATSBURG

NANTES

LYON

LUXEMBURG ART FAIR (Luxemburg)

ALLEEN GERESERVEERD VOOR GALERIES

MILAAN (Italië)

BARCELONA (Spanje)

REIMS

KORTRIJK (België)

DORTMUND (Duitsland)

MONACO

PARIJS

LUXEMBURG (Luxemburg)

HAUTE-SAVOIE

MARSEILLE

LAUSANNE ART FAIR (Zwitserland)

ALLEEN GERESERVEERD VOOR GALERIES

MULHOUSE

BRUSSEL (België)

BORDEAUX

17>19 januari 2025

24>26 januari 2025

07>09 februari 2025

28 feb.>02 maart 2025

07>09 maart 2025

21>23 maart 2025

27>30 maart 2025

04>06 april 2025

11>13 april 2025

25>27 april 2025

16>18 mei 2025

23>25 mei 2025

12>14 september 2025

19>21 september 2025

03>05 oktober 2025

10>12 oktober 2025

17>19 oktober 2025

30 okt.>02 november 2025

14>16 november 2025

21>23 november 2025

05>07 december 2025



**END OF
BLACK
SUMMER** -50%

CONTRACT VOOR DEELNAME VAN EXPOSANT

Deze aanvraag tot inschrijving wordt voorgelegd aan het selectiecomité. Dit artistieke comité waakt over de algemene kwaliteit van de tentoongestelde werken en het prestige van het evenement. Het comité beoordeelt de uitvoering van de werken niet, maar voert een selectie door die de geloofwaardigheid van de beurs moet waarborgen. Om die reden zal het comité een eventuele afwijzing niet aan de individuele aanvragers verantwoorden. Onderhuur van site aan artiesten is ten strengste verboden.

3^e EDITIE

art3f 

Internationale beurs voor hedendaagse kunst

KORTRIJK

16>18 Mei 2025
Kortrijk Xpo
Hal 5

Vrijdag 16:00-22:00 uur
Zaterdag van 10.00 tot 20.00 uur
Zondag 10.00-19.00 uur

VOORSTELLING VAN UW DOSSIER

Per mail aan :
info@art3f.com

Per post aan :
art3f
BP2271
68068 Mulhouse Cedex
France

Voor kunstenaars :

een CV, een biografie, uw artistieke loopbaan, uw laatste tentoonstellingen, 5 foto's van werken met vermelding van uw naam, de titel van het werk en het formaat.

Voor galeristen:

een informatieblad over uw galerie, 1 foto van werk per vertegenwoordigde kunstenaar.

Zodra uw aanvraag is goedgekeurd en aanvaard door de artistieke commissie, wordt het totale bedrag betaald na ontvangst van de factuur.

SCHILDER **BEELDHOUWER** **KERAMIST** **FOTOGRAAF**

ARTIST

Naam : Vornaam :

Artisten naam :

Adres

Postcode Stad

Land Tel.

GSM : E-mail :

Website :

VUL HET DEEL IN DAT U AANGAAT :

HR-nr : Andere statuten :

BTW-nr. Intracom :

GALERIE

Naam van de galerie

Naamen, voornaam van de verantwoordelijke(n)

.....

Adres

Postcode Stad

Land Tel.

GSM E-mail

Website

VERPLICHT :

HR-nr BTW-nr. Intracom

Aantal in de stand vertegenwoordigde kunstenaars

Namen van de kunstenaars

Hun discipline(s)

.....

.....

.....

.....

.....

.....

.....

.....

.....

.....

.....

.....

.....

.....

.....

.....

.....

.....

END OF BLACK SUMMER -50%

UW STAND

De prijs per m² omvat de houten wanden bekleed met wit geborsteld katoen, 1 spot van 300W voor 3m².

Let op! Om fouten te voorkomen, dient u alle velden in te vullen.

Indien u een elektriciteitskastje voor persoonlijk gebruik wenst (koelkast, computer of andere), **moet u de optie elektriciteitskastje aanvinken.**

KORTRIJK

A. STRUCTUUR

Prijs excl. BTW per m ² : 150 €	
Stand van : m ² x 150 € (minimaal 9 voor een kunstenaar, 18 voor een galerist) €
Hoek : 300 € per hoekx (1, 2, 3 ou 4 hoeken) <input type="checkbox"/> retour <input type="checkbox"/> open €
Totaal A € excl. BTW

B. INSCHRIJFGELD INCLUSIEF

Exposantenbadges (maximaal 2 voor kunstenaars / 4 voor galeries), 1 catalogus, 1 volledige pagina in onze catalogus, Uitnodigingen voor 2 personen Verzekering	
Totaal B	400 € excl. BTW

C. EXTRA OPTIES

Katoenen wandbekleding <input type="checkbox"/> wit gratis of <input type="checkbox"/> zwart 150 € of <input type="checkbox"/> grijs 150 € €
1 lineaire meter zijwand : 95 € x €
Melamine deur voor opslag : 290 € x €
1 m breed gordijn : 60 € x €
Extra 300W spot : 60 € x €
een schoenplaat 15 € per strekkende meter (voor de bevestiging van spots buiten muren) + paal 40 € (afhankelijk van de configuratie)	Raadpleeg ons
Electriciteitskast 1KW (voor aansluiting van diverse apparaten) : 340 € €
Plafond katoen per m ² : 25 € x €
Extra pagina in de catalogus: 190 € x €
Extra badge: 30 € x €
Totaal C € excl. BTW

SAMENVATTING VAN UW BESTELLING

Totaal = Totaal A + Totaal B (400 €) + Totaal C € excl. BTW
BTW (20%) €
Totaal +BTW € +BTW

UW GEWENSTE STANDPLAN

— = 1 meter

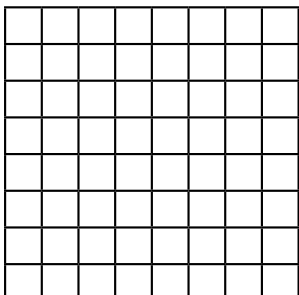

- PRIJS ALLEEN GELDIG ALS HET CONTRACT ONDERTEKEND EN VOLLEDIG INGEVULD WORDT GERETOURNEERD
- AANVRAGEN WORDEN VERWERKT IN DE VOLGORDE VAN BINNENKOMST.
- BINNEN DE GRENZEN VAN DE BESCHIKBARE STANDE DIE AAN DE AANBIEDING ZIJN TOEGEWEEZEN
- ELKE OPTIE DIE LATER WORDT TOEGEVOEGD, WORDT GEFACATUREERD TEGEN HET NORMALE TARIEF
- VOLLEDIGE BETALING BIJ ONTVANGST VAN DE FACTUUR

END OF BLACK SUMMER AANBIEDING
-50% (Totaal x 0,5)

..... € +BTW

*Aanbieding geldig tot 30 september 2024, onder voorbehoud van beschikbaarheid van de stands die aan deze aanbieding zijn toegewezen en niet cumuleerbaar met andere reeds lopende aanbiedingen (Discovery-aanbieding, Pack-aanbiedingen, Ledenaanbieding, etc.). Volledige betaling bij ontvangst van de factuur.

END OF
**BLACK
SUMMER** -50%

KORTRIJK

BETAALWIJZE

per cheque op naam van art3f per creditcard (per telefoon +33 (0)3 89 59 02 40)

per bankoverschrijving.

Bankcode	filiaal	Rekeningnummer	RIB sleutel	Domiciliëring
30087	33220	00020864001	88	CIC MULHOUSE SINNE
CIJFERTOETS : FR76 3008 7332 2000 0208 6400 188				CODE : CMCIFRPP

De BTW moet worden betaald door de buitenlandse exposanten, die deze vervolgens terugvorderen. Sinds 1 januari 2010 en krachtens artikel 7 van Richtlijn 2008/9/EG moet een verzoek om teruggaaf van btw worden ingediend via het elektronische portaal dat de bevoegde belastingautoriteit van de lidstaat van vestiging ter beschikking stelt. Vervolgens wordt het verzoek door de lidstaat van vestiging langs elektronische weg aan de lidstaat van teruggaaf toegezonden.

Een lijst van de bevoegde bureaus is te vinden op de website van de Commissie:

https://taxation-customs.ec.europa.eu/index_en

DATA EN TIJDEN

16-17-18 Mei 2025
Kortrijk Xpo - Hal 5
Doorniksesteenweg 216
8500 Kortrijk, België

Vrijdag: van 16.00 tot 22.00 uur

Zaterdag: 10 tot 20 uur

Zondag: 10u tot 19u

Montage

Donderdag vanaf 20 uur

en vrijdag vanaf 9 uur

Verplichte ontmanteling op zondag

vanaf 19.00 uur.

Vernissage

Vrijdag van 18.00 tot 22.00 uur

INFORMATIE

art3f wordt gehouden in het Parc Expo, en daarom gelden de regels van de beurzen van de federatie. De gehuurde stand wordt door de eigenaar(s) bezet van het begin tot het einde van het evenement tijdens de openingsuren. **U verbindt zich ertoe de stand niet af te breken voordat de bezoekers zijn vertrokken..**

In overleg met de curator zult u zich inspannen om uw expositiestukken te decoreren en te presenteren om het evenement cachet te geven, de ophangvoorschriften te respecteren, de schroeven uit de wanden te verwijderen wanneer u ze demonteert en u zult erop toezien dat u de wanden en de ter beschikking gestelde materialen niet beschadigt.

Een team zal gedurende de hele tentoonstelling technische ondersteuning bieden.

Ik heb het volgende reglement van de beurs gelezen en accepteer het zonder voorbehoud.

Het saldo van uw factuur moet worden betaald vóór

Naam :

Datum :

Handtekening en stempel :

Volledig dossier terug te sturen naar :

art3f

BP2271

68068 Mulhouse Cedex - France

Sollicitaties worden niet teruggestuurd, ook niet als ze worden afgewezen.

Voor meer informatie kunt u contact opnemen met

art3f op : +33 (0)3 89 59 02 40

of per e-mail: info@art3f.com

END OF BLACK SUMMER -50%

VOORBEELDEN VAN STANDS

Hier volgen enkele ideeën voor modules, opties en standindelingen. Dit zijn slechts voorbeelden, voel u vrij om uw stand naar uw wensen te ontwerpen met behulp van het rooster op pagina 2. De minimumdiepte is echter 3 meter. Mogelijke afmetingen (veelvouden van 3) : 9, 12, 15, 18, 21, 24, 27m2...

KORTRIJK

- scheidingswanden
- wanden voor kunstwerken
- ↑ spot

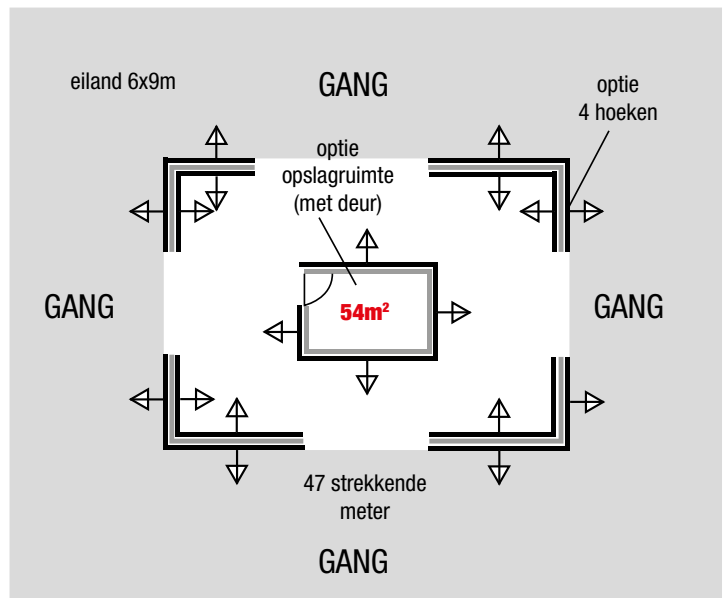
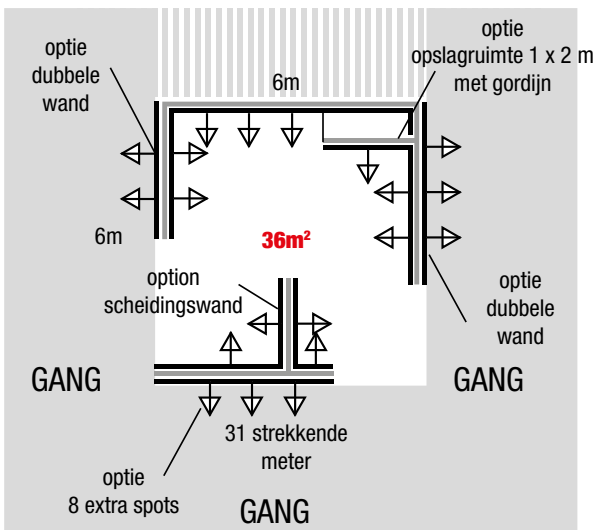
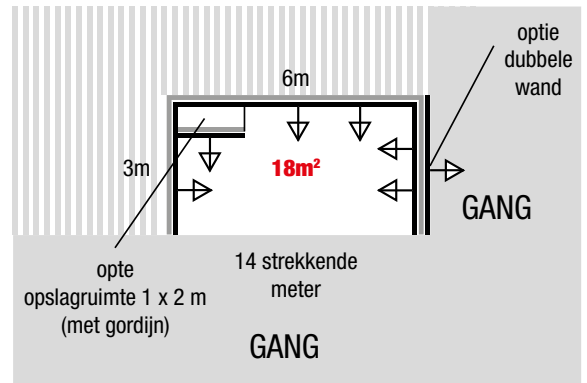
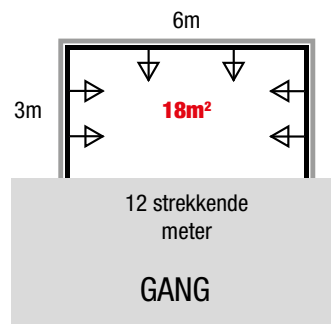
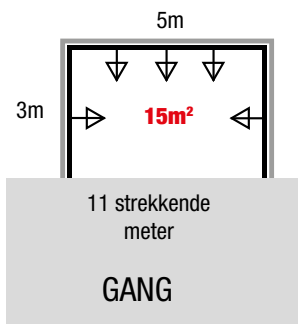
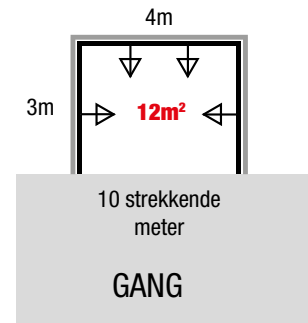
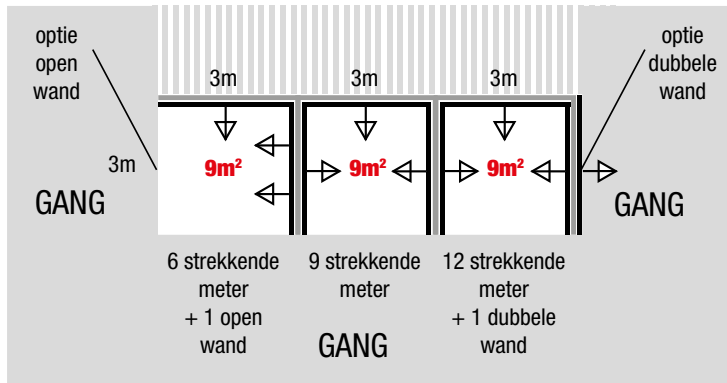

I. GENERAL PRESENTATION**Art. 1. Object of the show**

ART3F (the «Organizer») is organising a contemporary art fair (the «Salon») named after **art3f Kortrijk** will be held from 16 to 18 May 2025 with a vernissage on Friday from 6pm to 10pm. art3f will be open for general attendance Friday from 4PM, Saturday and Sunday from 10AM.

Any questions relating to the show (conditions of participation, progress, etc.) should be addressed to the Organizer (at the address listed at the top of this document).

Art. 2. Scope - contract documents

These General Terms and Regulations are enforceable against any exhibitor and candidate exhibitor. They are supplemented by the provisions in the exhibitors' application.

The transmission of the application for participation is worth accepting of these General Conditions and Internal Regulations. These General Terms and Regulations may, if necessary, be supplemented by any conditions put in place by the owner of the venue where the show is held.

Art. 3. General provisions

These General Terms apply as of right to the provision of a stand and the sale of works of art, art objects, as part of the show. The Organizer expressly reserves the right to unilaterally change these conditions at any time if circumstances require it and/or in the interest of the Show. In this case, these changes will be specified in a written document provided to exhibitors and will apply immediately and as of right. In the event of a breach of a stipulation of these terms and general conditions, all other stipulations will retain their full strength and scope.

In addition, the purpose of this regulation is also to define the rules for the admission and participation of exhibitors at ART3F show.

Candidate artists and contemporary art galleries receive a participation contract. They may be eligible to participate depending on the program they offer and subject to an available location for that program. Exhibitors agree to respect, without any restriction or restraint, the terms of this regulation and any new provisions that could be imposed by the circumstances and adopted by art3f in the interest of the fair.

Art. 4. Exhibitors

Exhibitors are the artists and professional galleries that officiate in the fields of painting, sculpture, photography, artistic glass, ceramics, publishers of art books, prints, lithographs, in the accepted definitions of original works, the media, the registry of commerce validating the activity. Exhibitors, French or foreign, who have selected a stand will have to respect the nomenclature of the elements allowed to be exhibited by the organizer.

II. TERMS OF PARTICIPATION - FINANCIAL CONDITIONS**Art. 5. Selection**

The applicant is asked to attach a complete file to the participation contract. Only artists nominated in the admissions file and who have been accepted by the selection committee will be able to be exhibited on the stand.

For artists : a Curriculum Vitae (resume), a biography, your artistic career, your latest exhibitions, 5 photos of works indicating your name, the title of the work and the format.

For gallery owners : an information sheet on your gallery, 1 photo of artwork per artist represented.

The Organizing Committee may accept or refuse the exhibitor without relying on a reason. Participation in one or more editions of art3f does not result in automatic admission for the following year.

Art. 6. Booking and settlement

The offer is valid until midnight on 30 June 2024. Once your application has been validated and accepted by the artistic committee, **full payment must be made upon receipt of the invoice.**

The exhibitor will be admitted to the fair after paying the

full fee due, and will then be able to take possession of the stand reserved for him.

In case of non-compliance with payment deadlines, any discounts will be cancelled and the entire invoice will be due. Parking fees may be applied depending on the location of the exhibition.

Art. 7. Non-acceptance

If your file is not accepted by the art committee, your registration file and attachments will not be returned to you. The organizer will proceed with the destruction of the data received from an unsuccessful exhibitor.

Art. 8. Cancellation

The balance of the rental amount is due after the application is accepted by the artistic committee. In the event of the exhibitor's withdrawal of membership, the exhibitor will remain liable for the entire location bill.

III. MATERIAL CONDITIONS**Art. 9. Allocation of stands**

The Organizer sets out the plan for the show. It distributes the stands taking into account, as far as possible, the wishes expressed by the exhibitors, the nature of the products and services they showcase, the planned layout of the stands and, if necessary, the date of acceptance of the orders.

The location of the stand assigned to an exhibitor is communicated to the exhibitor purely as an indication by means of a plan. It is up to the exhibitor to ensure that the plan is compliant before the installation of his stand, as the responsibility of the Organizer cannot be engaged in this regard.

Any complaint about the location of a booth must be notified in writing to the Organizer within eight days. After this time, no claims will be taken into account.

The Organizer expressly reserves the right to unilaterally change the surface area of a requested or allocated stand within 3% area up or down, as well as the layout of the corresponding areas, without change of price.

Art. 10. Occupying the site

The locations will be available for their set up by exhibitors from 9am Friday to Sunday at midnight.

Any unoccupied location on Friday by 1 p.m. may be assigned by the organizer to another exhibitor.

The exhibitor who was first attributed the site will not be entitled to compensation. Works arriving after the opening of the event may only be sent to the stands outside of open hours to the public. Locations after the demonstration must be vacated at midnight on Sunday. In case an exhibitor has not removed his goods within the allotted time, the organizer, for the security of the goods, to put those in custody at the fair's authorized carrier, at the expense of the exhibitor. Any additional damage and costs that may occur during this safety will not be the responsibility of the organizer. Each booth must be permanently occupied during the opening hours of the fair, last day included. Exhibitors must leave the sites, sets and equipment that were made available to them, in the state in which they received them.

Art. 11. Site layout

The layout of the stands is carried out according to the general plan drawn up by the Organizer. Any special arrangements must be authorized beforehand and in writing by the Organizer and must be carried out in strict compliance with the requirements of the technical file. Notwithstanding the above, the Organizer expressly reserves itself the right to request alterations or removals of developments that would negatively affect the general appearance of the Show or affect public traffic which would hinder neighbouring exhibitors; same for alterations or removals of developments that do not comply with the plan and model that has previously been submitted to the Organizer; all of this at the exclusive expenses of the exhibitor concerned. The specific decoration of the stands is carried out by the exhibitors under their exclusive responsibility. It must comply with the safety regulations issued by the public authorities as well as the general decoration plan and signage set out by the Organizer. The use of any sound, light or audiovisual process is prohibited, unless prior and written permission from the Organizer. Finally, the Organizer reserves the right to position an electric box (of varying

size and color) in your booth to power the lighting system and move the stand.

Art. 12. Cleaning

Cleaning and permanent maintenance of the floors (traffic, entrance and available areas on the floors) will be taken care of by the care of and be at the expense of the organizer. The exhibitor is responsible for the daily cleaning of his booth. Waste will have to be deposited in the aisles when the Showroom doors are closed - cleaning takes place at night.

Art. 13. Disassembly

The stand will have to be disassembled on Sunday evening from 7pm and released at midnight.

The partitions must be rendered without any support and hanging materials (screws). In case of non-compliance, you will be charged a minimum of 50 euros per partition by a cleaning crew.

IV. MISCELLANEOUS**Art. 14. Sales**

Sales are allowed during the event. However, for security reasons, no one is allowed to leave the hall of the fair with merchandise without an exit voucher describing the goods carried out, this voucher has to be signed by the exhibitor and acknowledged by the organizer.

Mandatory price display.

Mandatory display, in a visible way, on a panel in A3 format and in a character size that cannot be less than size 90, the following sentence: «The consumer does not have a right of retraction for any purchase made on this stand»

Cases of original works of art and objects of antiquity value:

According to Articles 4 and 5 of the December 3, 1987 Decree about the rights of buyers to Price Information and in accordance with the July 19, 1988 letter of application enforcing the provisions of the December 3, 1987 Decree, which provides accommodations for works of art: «Responding to the specifics of these products, it may be permissible to put a discreet label on items exposed to public view or, in art galleries, to consult a list of prices.»

Art.15. Security

All necessary measures will be taken by the organizer to ensure that the guarding of the fair outside the opening hours is effective. It is up to each exhibitor to exercise vigilant control over their own equipment or possessions during public hours, and during the assembly and dismantling of the stands. Exhibitors will be required to allow free access to electrical boxes located on or near their location.

Art. 16. Miscellaneous prohibitions

Unless expressly authorized by the organizer, exhibitors are prohibited:

- to rent all or part of their location free of charge, for payment or exchange of service
- to broadcast music in their booth or to use machines that could annoy other exhibitors.

V. INSURANCE**Art. 17. Insurance**

Apart from covering the risks of mandatory insurance, exhibitors must make sure with their usual company that they are covered for all other risks incurred, in particular theft, degradation of works or exhibition materials. Exhibitors absolve the organizers of any responsibility in the event of fire, explosion, flood, various disturbances, and for any element not attributable to the organizers, agents and attendants. In particular, the organizers cannot be asked for damages in the event that the rented package cannot be effectively used by exhibitors as a result of events of force majeure.

VI. CANCELLATION OF THE SHOW, POSTPONEMENT OF DATES, LIABILITY, TERMINATION**Art. 18. Cancellation of the show or postponement of dates**

In the event of cancellation of the show for reasons beyond the Organizer's control, accepted orders will be maintained as of right and without formalities, excluding any compensation. In the event of cancellation of the show or date lag, for reasons beyond the organizer's control, exhibitors will not be entitled to any refund or compensation.

Art. 19. Limitation of liability

Each exhibitor is solely responsible for complying with the regulations applicable to his activity to the works and objects of art he sells (particularly in relation to all required customs formalities), for his commercial offers, as well as for the accuracy of any information transmitted to the Organizer, especially for the needs of the show's communication material.

It therefore guarantees the Organizer against the consequences of any appeals or claims in this respect. The Organizer's proven liability is expressly limited to the repair of direct property damage, exclusive of any intangible and/or indirect damage, such as, in particular and without limitation, loss of turnover, operating loss, commercial or image damage, etc., subject to any mandatory legal or regulatory provision. In addition, and in all cases where the law permits such a limitation, the overall responsibility of the Organizer in connection with the provision of a stand and/or the sale of communication tools is expressly limited to the sums actually paid by the exhibitor in that capacity.

Art. 20. Termination

Any failure by the exhibitor to comply with any of his obligations under these terms and/or orders and/or registration file will, as of right and without prior notice, result in the immediate termination of the services ordered and the exclusion of the exhibitor from the show. In this case, the exhibitor will not be entitled to any refund and will be liable as a matter of law to the Organizer for compensation equal to 25% of the price of the stand made available to him, as a criminal clause, notwithstanding the allocation of the so-called stand to another exhibitor.

Art. 21. Responsibility of the organisers

1. As the availability of the exhibition centres may change according to their calendar, this date may be changed, although this is exceptional and will not lead to cancellation of the contract or payment of compensation.
2. Furthermore, in case of force majeure (transportation strike, viruses, epidemics, pandemics, natural disasters...) the organizers can postpone the fair, change its opening hours, exclude the public. They can cancel or close it before the scheduled date. In all cases, contracts with exhibitors remain valid and payment for booth rentals and other services is due. In addition, the organizer is free of reimbursement of any ancillary expenses (hotel, transport, etc.).

VII. APPLICABLE LAW, ATTRIBUTION OF JURISDICTION**Art. 22. Claims**

Exhibitors' claims must be submitted, for the purpose of an amicable settlement, to the organizer by registered letter with acknowledgement of receipt within 15 days of the closing of the fair. After this period, claims will no longer be admissible. Any dispute will fall exclusively within the jurisdiction of the Mulhouse courts and will be subject to French law. For the interpretation of the regulation, only French text is authoritative.